

# Mounting Bracket for bus bar 1, 2-Poles

Data Solutions

CATALOG NUMBER

---

**20100-028**

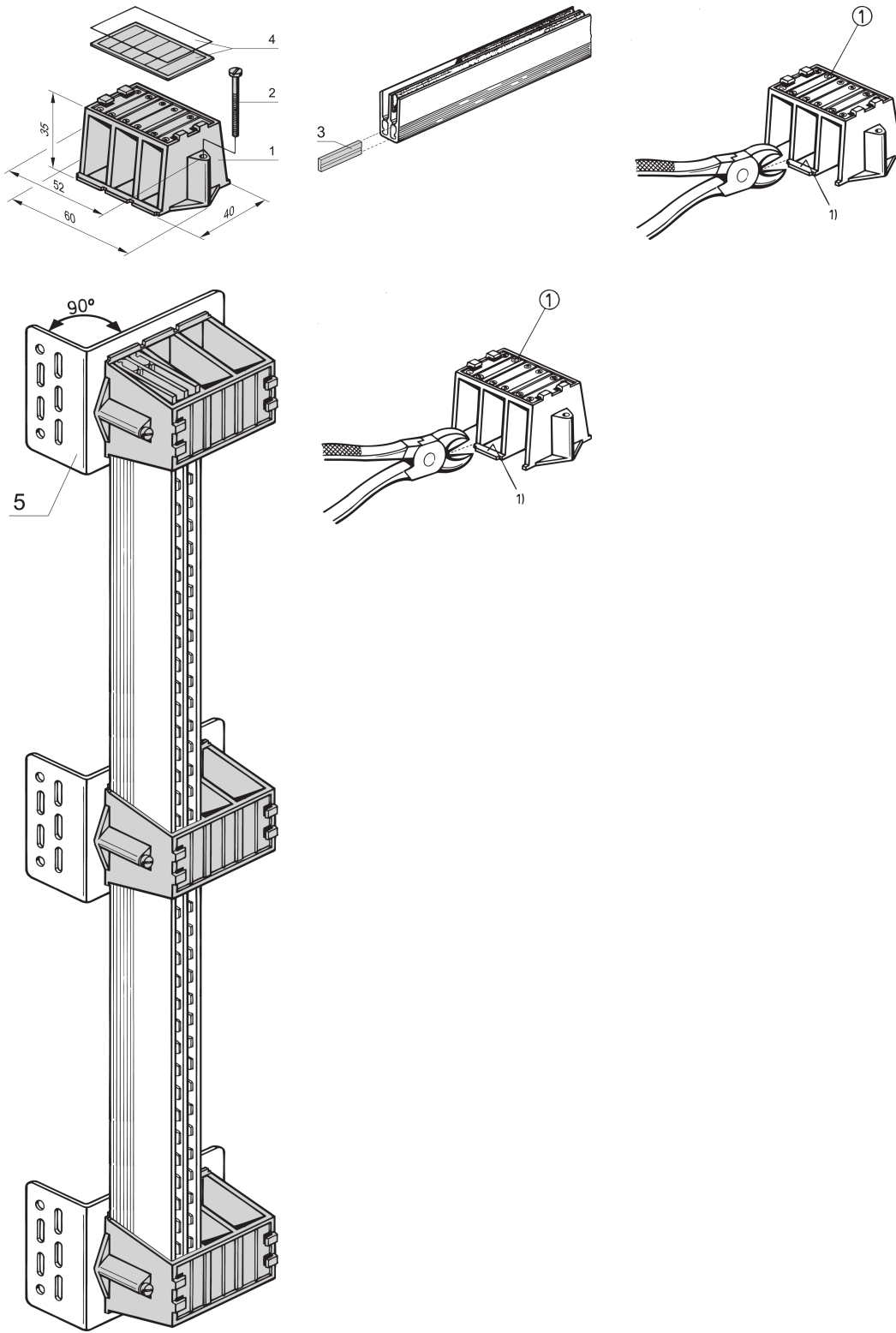

Mounting Bracket for Busbar 1, 2-Pole.

**CERTIFICATIONS**



## FEATURES

---

Mounting Brackets for Busbars or Busbar Modules are load circuit isolated mounting units for grounding rails. There may be adapters with assigned current ratings which supply the load current to loadfeeders through wire connections.

## PRODUCT ATTRIBUTES

---

Product Type: Bracket

Type: Mounting Bracket

Works With: Busbars

Material: Polyphenylene Ether

Package Quantity: 4

Net Weight: 0.07kg

## ADDITIONAL PRODUCT DETAILS

---

For reasons of stability a fixing bracket should be fitted at 500 mm intervals.

## WARNING

---

nVent products shall be installed and used only as indicated in nVent's product instruction sheets and training materials. Instruction sheets are available at [www.nvent.com](http://www.nvent.com) and from your nVent customer service representative. Improper installation, misuse, misapplication or other failure to completely follow nVent's instructions and warnings may cause product malfunction, property damage, serious bodily injury and death and/or void your warranty.



Our powerful portfolio of brands:

**CADDY ERICO HOFFMAN ILSCO SCHROFF TRACHTE**